



HIGH ENERGY CENTRIFUGAL BARREL MACHINES VKDT SERIES

Santrifüj Tambur YüzeY İşlem Makineleri
The ideal solution for deburring and polishing
the surface of mass produced parts

Yapılan İşlemler Transactions

Çapak Alma / Deburring
Parlatma / Polishing
Köşe Kıрма / RADIUSING
Yağ Alma / Oil Cleaning
Pas Alma / Rust Cleaning
Oksit Açma / Antic Oxide
Tufal Alma / Descaling
Yıkama / Cleaning
Polisaj

İşlenen Malzemeler Materials Applications

Alüminyum / Aluminium
Demir-Çelik / Iron-Steel
Bakır / Copper
Pirinç / Brass
Zamak / Zamak
Toz Metal / Powder Metal
Altın-Gümüş / Gold-Silver
Kurşun / Lead
Titanyum / Titanium
ABS & Polyester
Kauçuk / Rubber
Akrilik / Acrylic
Bakalit / Bacalite
Paslanmaz Çelik / Stainless Steel
Hassas Döküm / Precision Casting

Kullanım Alanları Applications Areas

Mobilya aksesuar parçaları
Furniture accessory parts
Sac Pres Parçaları
Sheet metal press parts
Enjeksiyon, savurma, kum, kokil, döküm parçaları
Injection molding, centrifugal, sand, gravity die casting parts
Her türlü talaşlı imalat parçaları
All kinds of parts machining
Armatür ve vana parçaları
Fitting and valve parts
Çatal, kaşık, bıçak
Fork, spoon, knife
Tıbbi ve cerrahi aletler
Medical and surgical instruments
Akrilik diş ve diğer parçalar
Acrylic teeth and other dental parts
Otomotiv sanayi parçaları
Automotive parts industry
Havacılık ve uçak endüstri ürünleri
Aviation and aircraft industry
Kuyumculuk ve mücevher parçaları
Jewelry parts
Bijuteri ve aksesuar parçaları
Costume jewelry and accessory parts
Mermer ve doğal taş eskitme
Tumbled marble and natural stone

Adres:

Kemalpaşa Mh. Çanakkale Cd.
No:41E Pınarbaşı / Bornova / İzmir
info@adayuzey.com
www.adayuzey.com

Vibromak
Ege Bölge Yetkili Bayi

TURKEY
Discover
the potential

Santrifüj Tambur Yüze İşlem Makineleri High Energy Centrifugal Barrel Surface Finishing Machine



VKDT 18

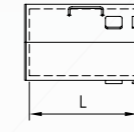
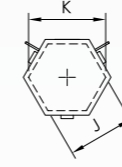

VKDT 30

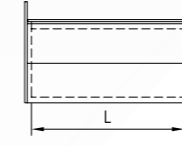
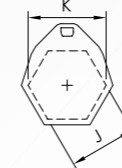

VKDT 140

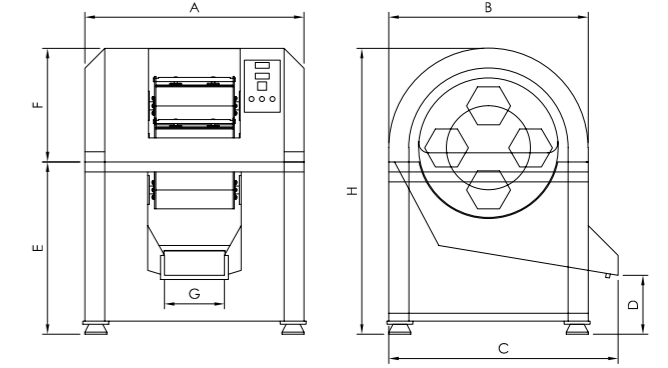
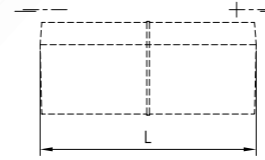
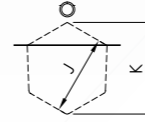

VKDT 18 / VKDT 30

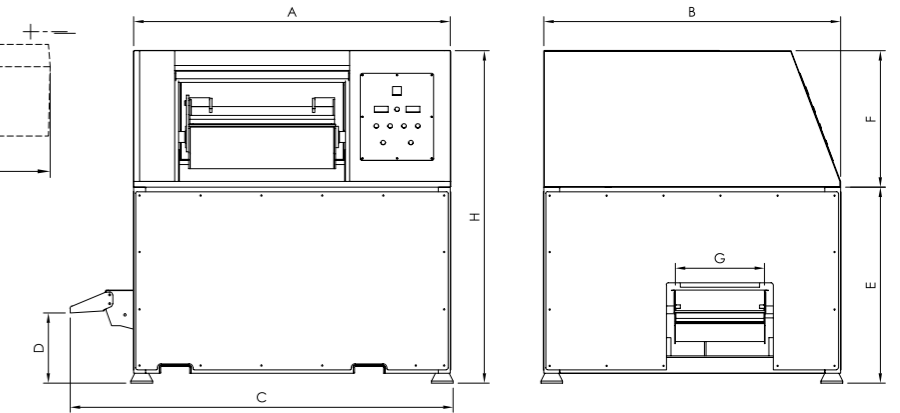

VKDT 140

VKDT serisi santrifüj tambur yüze işleme makineleri özellikle küçük hacimli metal ve metal dışı malzemelerden mamül parçaların yüze işlemlerinde kullanılır. Bu seri makineler vibrasyon makinelerine göre daha hızlı ve kısa sürede yüze işleme sonuçları elde etmeyi sağlar.

VKDT series machines can be used for surface finishing of small volume metal and nonmetal work pieces. These type of machines finishing process are more faster and effective than the vibratory machines finishing process.



VKDT 30 Box External View
VKDT 30 Kutu Dış Görünümü



VKDT 30 Box Internal View
VKDT 30 Kutu İç Görünümü



Electric Control Panel
Elektrik Panosu

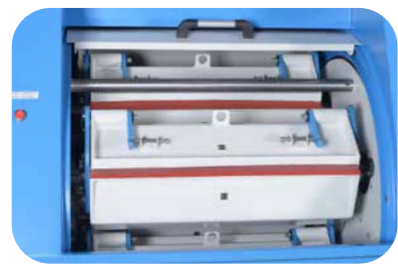

VKDT 140 Box External View
VKDT 140 Kutu Dış Görünümü



VKDT 140 Box Internal View
VKDT 140 Kutu İç Görünümü



VKDT 140 Vibratory Separator
Vibrasyon Elek

Teknik Ölçüler Technical Dimensions

TİP / TYPE		VKDT 18	VKDT 30	VKDT 140
Brüt Hacim Gross Volume	Lt	4,5 x 4	7,5 x 4	35 x 4
Toplam Motor Gücü Total Motor Power	Kw	1,5	2,75	6,65
Çalışma Devri Operating Speed	rpm	0-210	0-180	0-140
Max. İş Parçası Ebadı Max. Work Part Dimension	mm	230	380	600
Ağırlık Weight	Kg	280	440	1470
A	mm	770	1100	1600
B	mm	900	1000	1500
C	mm	1000	1150	1940
D	mm	--	300	355
E	mm	760	870	990
F	mm	615	570	690
G	mm	--	300	450
H	mm	1380	1440	1680
J	mm	160	165	240
K	mm	180	190	275
L	mm	260	340	650

Tüm ölçüler milimetredir.
All dimensions are millimeters.

Vibromak makinelerinin renk ve teknik değerlerinin değişim hakkını saklı tutar.
Vibromak reserves the right for changing the colors and technical values of the machines.